



SIGMA

Panoramic Cabin for Solon Premium

Company restricted information

Reaching New Heights

SIGMA Current Offering



Duty Map ➤ Solon Premium (code=OTHER / EN81_20_2014)

Square(OC): C02, C04

Round(OR): A03, A04, A05

Diamond(OD): B01, B05

Specification		Square			Round/Diamond		
Speed (m/s)		1	1.5	1.75	1	1.5	1.75
Duty Load (kg)	800(10)						
	1000(13)						
	1150(15)						
	1350(18)						

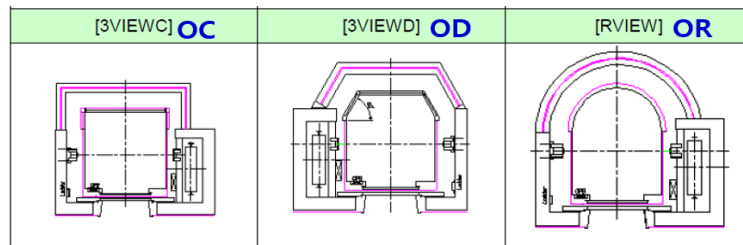

OE Offering Dimensions



Square Type

Capacity		Entrance Opening (mm)	Opening Type	Car Inside Size (mm)		Hoistway Size (mm)	
Person	Load(kg)			CW	CD	HW	HD
10	800	800	Center	1400	1350	2050	1750
13	1000	900	Center	1600	1400	2250	1800
15	1150	1000	Center	1600	1550	2550	2100
18	1350	1100	Center	1750	1650	2750	2200

Round / Diamond Type

Capacity		Entrance Opening (mm)	Opening Type	Car Outside Size (mm)		Hoistway Size (mm)	
Person	Load(kg)			Width	Depth	HW	HD
13	1000	900	Center	1400	2000	2150	2400
18	1350	1100	Center	1550	2350	2550	2650

Note 1: For the Round / Diamond Type, "Car Outside Size" can be offered.

OE Offering for Square

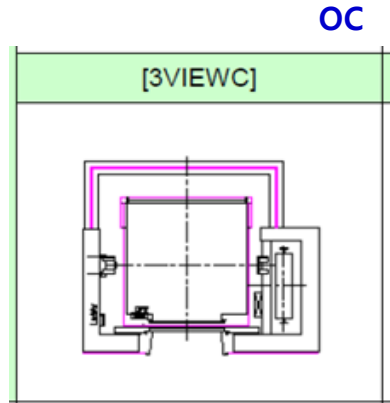

OE Offering for Round

OR

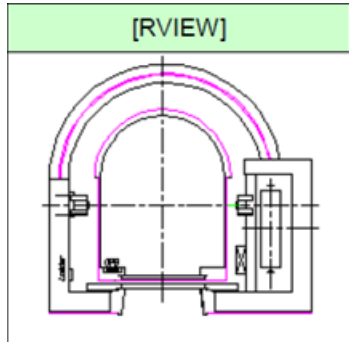

A03



A04



A05



OE Offering for Diamond

OD

[3VIEWD]

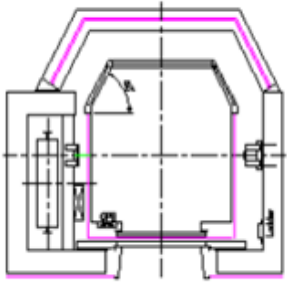

B01



B05



Effect



Configuration

- Rear panel panoramic glass
- Up and down enclosure – baking steel & hairline st. st. & decorative light
- Ceiling - CL-33/CL-39/CL-39; (effect for reference only)
- Car wall - hairline st. st. and curved glass; (Opt : Mirror/Ti-mirror/Ti-hairline st. st.)
- Handrail - HR01 STS single tube
- Flooring – PVC (others please contact OE IBD)

Ceiling:

CL-39 (std).



CL-33



CL-38



Effect

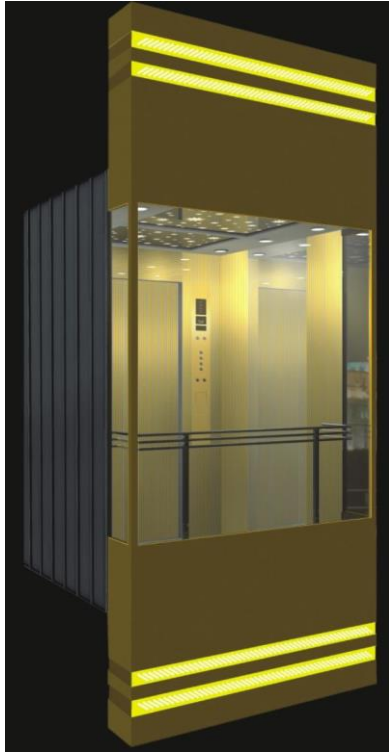

Configuration

- Rear panel panoramic glass
- Up and down enclosure – baking steel & decorative light
- Ceiling - CL-33/CL-39/CL-38; (effect for reference only)
- Car wall - hairline st. st. and curved glass; (Opt : Mirror/Ti-mirror/Ti-hairline st. st.)
- Handrail – JQ-E013
- Flooring – PVC (others please contact OE IBD)

Ceiling:

CL-39 (std).



CL-33



CL-38



Effect



Configuration

- Rear panel curved panoramic glass (3 pcs)
- Up and down enclosure – baking steel & decoration light
- Ceiling - CL-65 (std), electrostatic spraying steel;
- Car wall - hairline st. st. and curved glass; (Opt : Mirror/Ti-mirror/Ti-hairline st. st.)
- Handrail - HR01 STS single tube; (Opt : HR03 STS double tube)
- Flooring – PVC (others please contact OE IBD)

Ceiling:

CL-65 (std).

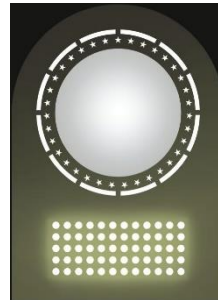

CL-66



CL-63 .



CL-64 .

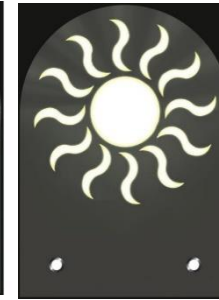

Effect



Configuration

- Rear panel curved panoramic glass (3 pcs)
- Up and down enclosure – hairline st. st;
- Ceiling - CL-63/ CL-64/ CL-65/ CL-66, electrostatic spraying steel; (effect for reference only)
- Car wall - hairline st. st. and curved glass; (Opt : Mirror/Ti-mirror/Ti-hairline st. st.)
- Handrail - 1 sides HR01 STS single tube; (Opt : HR03 STS double tube)
- Flooring – PVC (others please contact OE IBD)

Ceiling:

CL-63 .



CL-64 .



CL-65 .

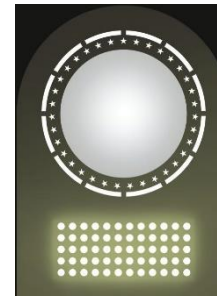

CL-66

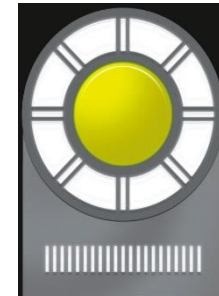

Effect



Configuration

- Rear panel curved panoramic glass (3 pcs)
- Up and down enclosure – hairline stainless steel;
- Ceiling - CL-63/ CL-64/ CL-65/ CL-66, electrostatic spraying steel; (effect for reference only)
- Car wall - hairline st. st. and curved glass; (Opt : Mirror/Ti-mirror/Ti-hairline st. st.)
- Handrail - HR03 STS double tube; (Opt : HR01 STS single tube)
- Flooring – PVC (others please contact OE IBD)

Ceiling:

CL-63 .



CL-64 .



CL-65 .

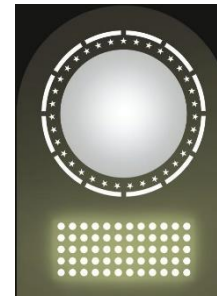

CL-66

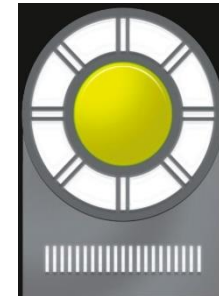

Effect



Configuration

- Rear panel rhombic panoramic glass
- Up and down enclosure – Acrylic & baking steel & decoration light
- Ceiling - CL-71/CL-72/ CL-73, hairline stainless steel frame; (effect for reference only)
- Car wall - hairline st. st. and rhombic panoramic glass; (Opt : Mirror/Ti-mirror/Ti-hairline st. st.)
- Handrail - 3 sides JQ-E014; (hairline/mirror STS)
- Flooring – PVC (others please contact OE IBD)

Ceiling:

CL-71

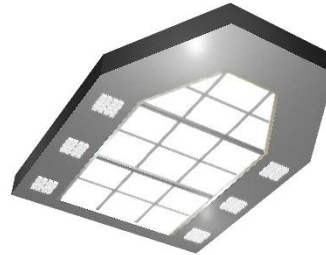

CL-72

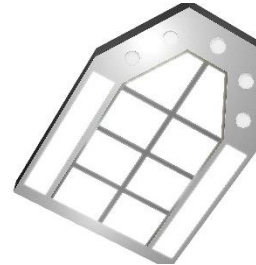

CL-73

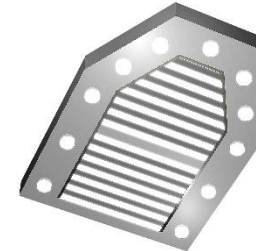

Effect



Configuration

- Rear panel rhombic panoramic glass
- Up and down enclosure –baking steel
- Ceiling - CL-71/CL-72/ CL-73, hairline stainless steel frame; (effect for reference only)
- Car wall - hairline st. st. and rhombic panoramic glass; (Opt : Mirror/Ti-mirror/Ti-hairline st. st.)
- Handrail - 3 sides JQ-E014; (hairline/mirror STS)
- Flooring – PVC (others please contact OE IBD)

Ceiling:

CL-71

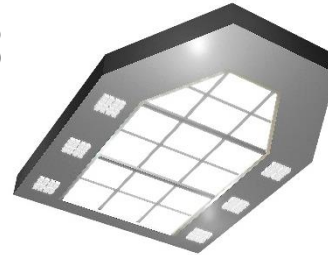

CL-72

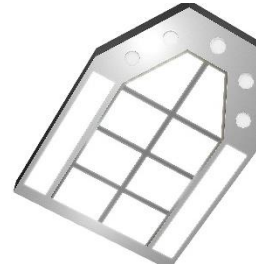

CL-73

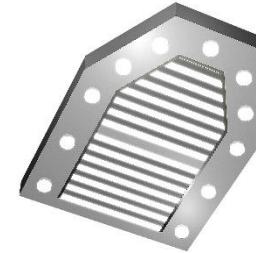

OE Handrail Options

**HR01HL/ HR01POL stainless steel
single tube**



**HR03HL/ HR03POL stainless steel
double tube**



-HL : Hairline st. st. finishes

-POL : Mirror st. st. finishes

Floor Options

➤ PVC 3mm



DE103



DE111



DE114



DE313



DE2106



DT01

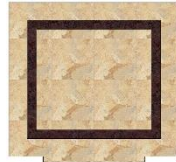

DT03

➤ By user

Recess 3/20/25/30mm



SIGMA

Reaching New Heights